

AU OPTRONICS CORPORATION

Product Specification

12.1” WXGA Color TFT-LCD Module

Model Name: B121EW03 V2

| | |
|--------------------|-------------------------|
| Approved by | Prepared by |
| <i>Joselyn Liu</i> | <i>Jeffrey SY Hsiao</i> |

NBBU Marketing Division / AU Optronics corporation

| | |
|----------|-----------------------|
| Customer | Checked & Approved by |
| Dell | |

Product Specification

12.1" WXGA Color TFT-LCD Module Model Name: B121EW03 V.2

() Preliminary Specifications
(V) Final Specifications

Note: This Specification is subject to change without notice.

Contents

| | |
|---|-----------|
| 1. Handling Precautions..... | 5 |
| 2. General Description..... | 6 |
| 2.1 Display Characteristics | 6 |
| 2.2 Optical Characteristics | 7 |
| 3. Functional Block Diagram | 12 |
| 4. Absolute Maximum Ratings..... | 13 |
| 4.1 Absolute Ratings of TFT LCD Module | 13 |
| 4.2 Absolute Ratings of Backlight Unit | 13 |
| 4.3 Absolute Ratings of Environment | 13 |
| 5. Electrical characteristics | 14 |
| 5.1 TFT LCD Module | 14 |
| 5.2 Backlight Unit | 16 |
| 6. Signal Characteristic | 18 |
| 6.1 Pixel Format Image | 18 |
| 6.2 The input data format | 19 |
| 6.3 Signal Description | 20 |
| 6.4 Interface Timing..... | 22 |
| 7. Connector & Pin Assignment..... | 24 |
| 7.1 TFT LCD Module | 24 |
| (B) Signal Pin | 24 |
| 7.2 Backlight Unit | 25 |
| 7.3 Signal for Lamp connector | 25 |
| 8. Vibration and Shock Test | 26 |
| 8.1 Vibration Test..... | 26 |
| 8.2 Shock Test Spec:..... | 26 |
| 9. Reliability | 27 |
| 10. Mechanical Characteristics | 28 |
| 10.1 LCM Outline Dimension | 28 |
| 10.2 Screw Hole Depth and Center Position..... | 30 |
| 11. Shipping and Package | 31 |
| 11.1 Shipping Label Format | 31 |
| 11.2. Carton package | 32 |
| 11.3 Shipping package of palletizing sequence | 32 |
| 12. Appendix: EDID description | 33 |



Record of Revision

| Version and Date | Page | Old description | New Description | Remark |
|------------------|-----------|--|---|--------|
| 0.1 2005/12/05 | All | First Edition for Customer | | |
| 0.2 2005/12/15 | 6 | Glare, Hardness 2H, Haze 25%, Reflectance 4.3% | Glare, Hardness 3H, Reflectance 4.3% | |
| 0.2 2005/12/15 | 14 | | VDD power Max 1.6 watt | |
| 0.3 2006/4/07 | 6 | 180 typ. (5 points average) 160 min. (5 points average) | 200 typ. (5 points average) 170 min. (5 points average) | |
| 0.3 2006/4/07 | 6 | Contrast ratio 400 typ | 500 typ. | |
| 0.3 2006/4/07 | 7 | White Luminance CCFL 6.0mA (5 points average) 180 typ. / 160 min. | White Luminance CCFL 6.0mA ((5 points average) 200 typ. / 170 min. | |
| 0.3 2006/4/07 | 7 | Viewing angle Vertical CR = 10 (Upper) 10 (Lower) 30 | Viewing angle Vertical CR = 10 (Upper) 20 (Lower) 40 | |
| 0.3 2006/4/07 | 7 | | Update Color / Chromaticity Coordinates (CIE 1931) | |
| 0.3 2006/4/07 | 7 | CR: Contrast Ratio typ 400 | CR: Contrast Ratio typ 500 | |
| 0.3 2006/4/07 | 22 | 6.4.1 Clock frequency: 68.9 (typ) | 6.4.1 Clock frequency: 68 (typ) | |
| 0.3 2006/4/07 | 31 | 11.1 Shipping Label Format (Rev. X20) | 11.1 Shipping Label Format (Rev. A00) | |
| 0.3 2006/4/07 | 33 | | Update 12. Appendix: EDID description | |
| | | | | |



1. Handling Precautions

- 1) Since front polarizer is easily damaged, pay attention not to scratch it.
- 2) Be sure to turn off power supply when inserting or disconnecting from input connector.
- 3) Wipe off water drop immediately. Long contact with water may cause discoloration or spots.
- 4) When the panel surface is soiled, wipe it with absorbent cotton or other soft cloth.
- 5) Since the panel is made of glass, it may break or crack if dropped or bumped on hard surface.
- 6) Since CMOS LSI is used in this module, take care of static electricity and insure human earth when handling.
- 7) Do not open nor modify the Module Assembly.
- 8) Do not press the reflector sheet at the back of the module to any directions.
- 9) In case if a Module has to be put back into the packing container slot after once it was taken out from the container, do not press the center of the CCFL Reflector edge. Instead, press at the far ends of the CFL Reflector edge softly. Otherwise the TFT Module may be damaged.
- 10) At the insertion or removal of the Signal Interface Connector, be sure not to rotate nor tilt the Interface Connector of the TFT Module.
- 11) After installation of the TFT Module into an enclosure (Notebook PC Bezel, for example), do not twist nor bend the TFT Module even momentarily. At designing the enclosure, it should be taken into consideration that no bending/twisting forces are applied to the TFT Module from outside. Otherwise the TFT Module may be damaged.
- 12) Cold cathode fluorescent lamp in LCD contains a small amount of mercury. Please follow local ordinances or regulations for disposal.
- 13) Small amount of materials having no flammability grade is used in the LCD module. The LCD module should be supplied by power complied with requirements of Limited Power Source(, IEC60950 or UL1950), or be applied exemption.
- 14) The LCD module is designed so that the CFL in it is supplied by Limited Current Circuit(IEC60950 or UL1950). Do not connect the CFL in Hazardous Voltage Circuit.

2. General Description

B121EW03 V2 is a Color Active Matrix Liquid Crystal Display composed of a TFT LCD panel, a driver circuit, and backlight system. The screen format is intended to support the WXGA (1280(H) x 800(V)) screen and 262k colors (RGB 6-bits data driver). All input signals are LVDS interface compatible. Inverter card of backlight is not included.

B121EW03 V2 is designed for a display unit of notebook style personal computer and industrial machine.

2.1 Display Characteristics

The following items are characteristics summary on the table under 25 °C condition:

| Items | Unit | Specifications |
|--------------------------------------|----------------------|---|
| Screen Diagonal | [mm] | 307.9 (12.1W") |
| Active Area | [mm] | 261.12(H) X 163.2(V) |
| Pixels H x V | | 1280x3(RGB) x 800 |
| Pixel Pitch | [mm] | 0.204X0.204 |
| Pixel Arrangement | | R.G.B. Vertical Stripe |
| Display Mode | | Normally White |
| Typical White Luminance (ICFL=6.0mA) | [cd/m ²] | 200 typ. (5 points average) 170 min. (5 points average) (Note1) |
| Luminance Uniformity | | 1.25 max. (5 points) |
| Contrast Ratio | | 500 typ. |
| Optical Rise Time/Fall Time | [msec] | 10/15 typ. |
| Nominal Input Voltage VDD | [Volt] | +3.3 typ. |
| Typical Power Consumption | [Watt] | 4.5W max. |
| Weight (without inverter) | [Grams] | 250g typ 265g max |
| Physical Size | [mm] | 275.82x 178 x 5.2 max. |
| Electrical Interface | | 1 channel LVDS |
| Surface Treatment | | Glare, Harness 3H, Reflectance 4.3% |
| Support Color | | Native 262K colors (RGB 6-bit data driver) |

Product Specification

| | | |
|--------------------------------|------|-----------------|
| Temperature Range Operating | [°C] | 0 to +50 |
| Storage (Non-Operating) | [°C] | -40 to +60 |
| RoHS Compliance | | RoHS Compliance |

2.2 Optical Characteristics

The optical characteristics are measured under stable conditions at 25°C (Room Temperature):

| Item | Unit | Conditions | Min. | Typ. | Max. | Note |
|---|----------------------|--------------------------------------|-------|-------|-------|-------|
| White Luminance CCFL 6.0mA | [cd/m ²] | 5 points average | 170 | 200 | - | 1,2,3 |
| Viewing Angle | [degree] | Horizontal (Right) CR = 10 (Left) | - | 40 | - | 2,7 |
| | [degree] | | - | 40 | - | |
| | [degree] | Vertical (Upper) CR = 10 (Lower) | - | 20 | - | |
| | [degree] | | - | 40 | - | |
| Uniformity | | 5 Points | | | 1.25 | 1 |
| Uniformity | | 13 Points | | | 1.6 | |
| CR: Contrast Ratio | | | 350 | 500 | - | 6 |
| Cross talk | % | | | | 4 | 4 |
| Response Time | [msec] | Rising | - | 10 | 15 | 5 |
| | [msec] | Falling | - | 15 | 20 | |
| | [msec] | Raising + Falling | | 25 | 35 | |
| Color / Chromaticity Coordinates (CIE 1931) | | Red x | 0.560 | 0.580 | 0.600 | 2,7 |
| | | Red y | 0.320 | 0.340 | 0.360 | |
| | | Green x | 0.290 | 0.310 | 0.330 | |
| | | Green y | 0.530 | 0.550 | 0.570 | |
| | | Blue x | 0.135 | 0.155 | 0.175 | |
| | | Blue y | 0.135 | 0.155 | 0.175 | |
| | | White x | 0.283 | 0.313 | 0.343 | |
| | | White y | 0.299 | 0.329 | 0.359 | |

Note 1: 5 points position (Display area : 261.12mm x 163.2mm)

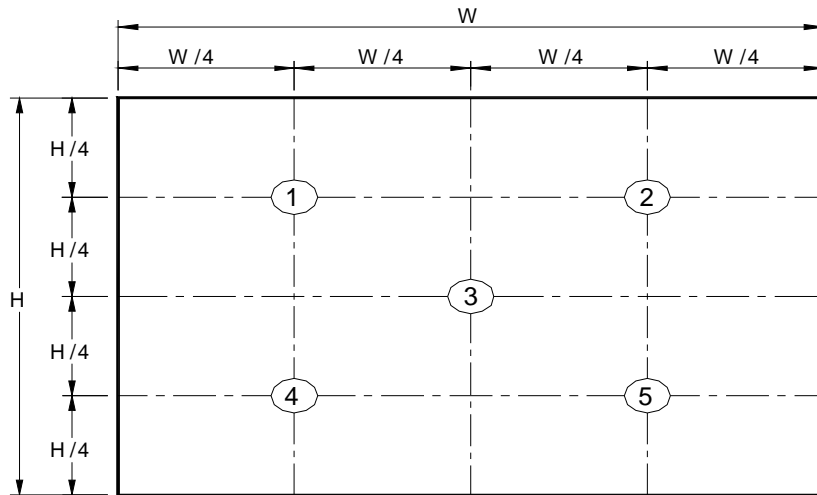

Note 2: 13 points position

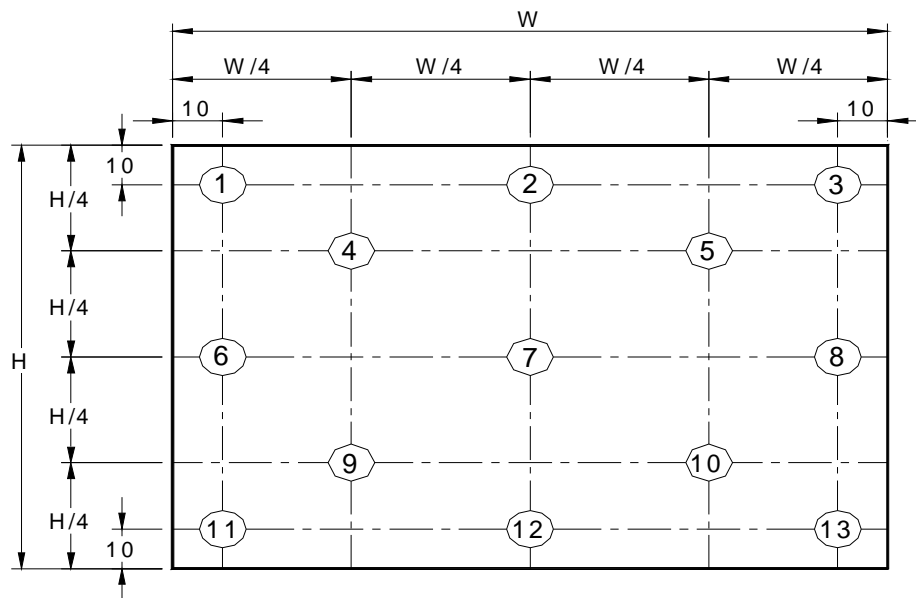

Note 3: The luminance uniformity of 5 and 13 points is defined by dividing the maximum luminance values by the minimum test point luminance

$$\delta_{W5} = \frac{\text{Maximum Brightness of five points}}{\text{Minimum Brightness of five points}}$$

$$\delta_{W13} = \frac{\text{Maximum Brightness of thirteen points}}{\text{Minimum Brightness of thirteen points}}$$

Note 4: Measurement method

The LCD module should be stabilized at given temperature for 30 minutes to avoid abrupt temperature change during measuring. In order to stabilize the luminance, the measurement should be executed after lighting Backlight for 30 minutes in a stable, windless and dark room.

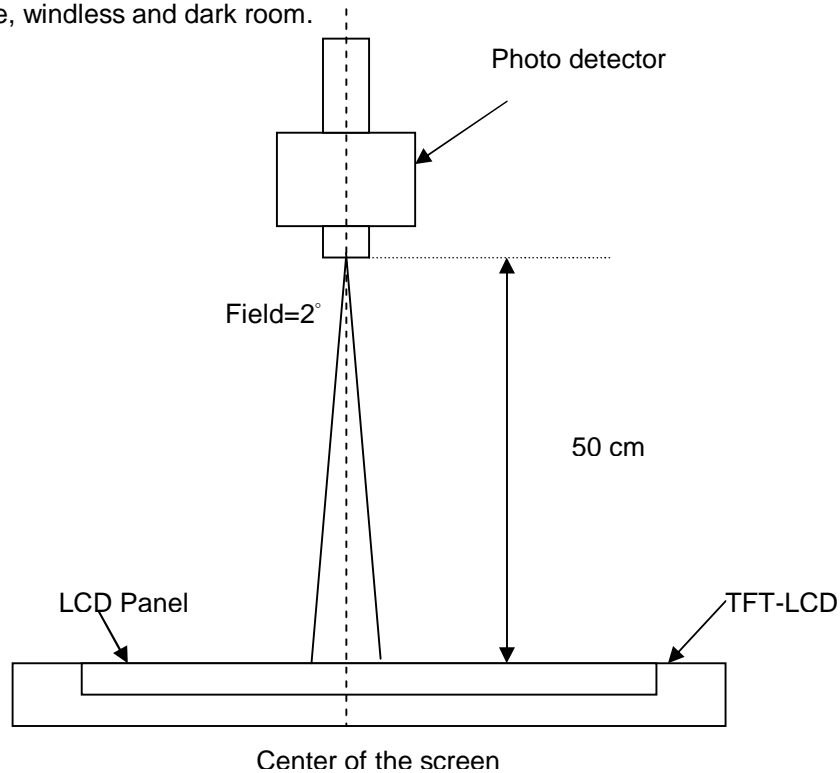

Note 5 : Definition of Cross Talk (CT)

$$CT = | Y_B - Y_A | / Y_A \times 100 (\%)$$

Where

Y_A = Luminance of measured location without gray level 0 pattern (cd/m²)

Y_B = Luminance of measured location with gray level 0 pattern (cd/m²)

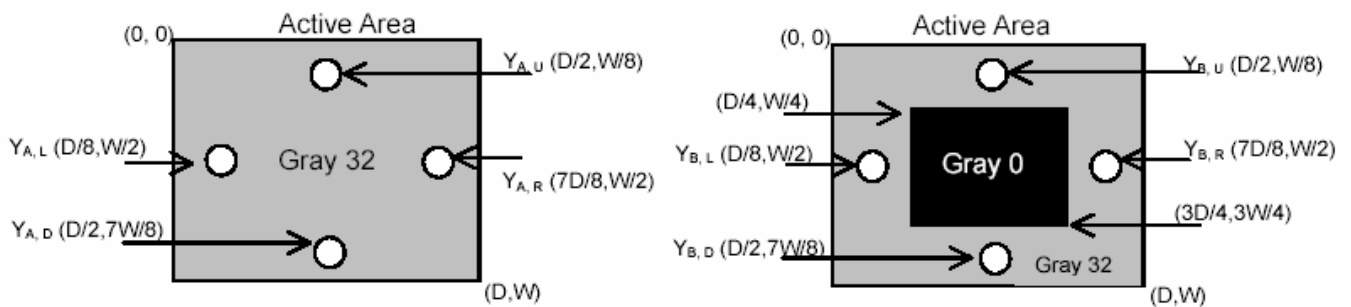

Note 6: Definition of response time:

The output signals of BM-7 or equivalent are measured when the input signals are changed from "Black" to "White" (falling time) and from "White" to "Black" (rising time), respectively. The response time interval between the 10% and 90% of amplitudes. Refer to figure as below.

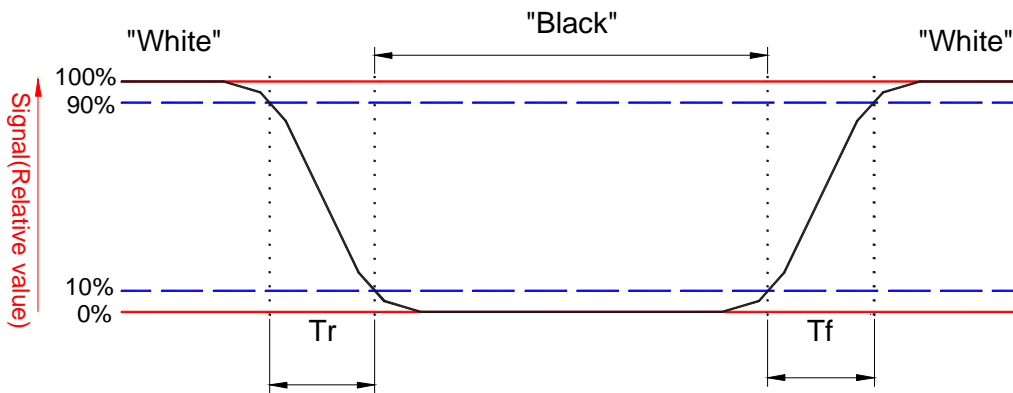

Note 7. Definition of viewing angle

Viewing angle is the measurement of contrast ratio ≥ 10 , at the screen center, over a 180° horizontal and 180° vertical range (off-normal viewing angles). The 180° viewing angle range is broken down as follows; 90° (θ) horizontal left and right and 90° (Φ) vertical, high (up) and low (down). The measurement direction is typically perpendicular to the display surface with the screen rotated about its center to develop the desired measurement viewing angle.

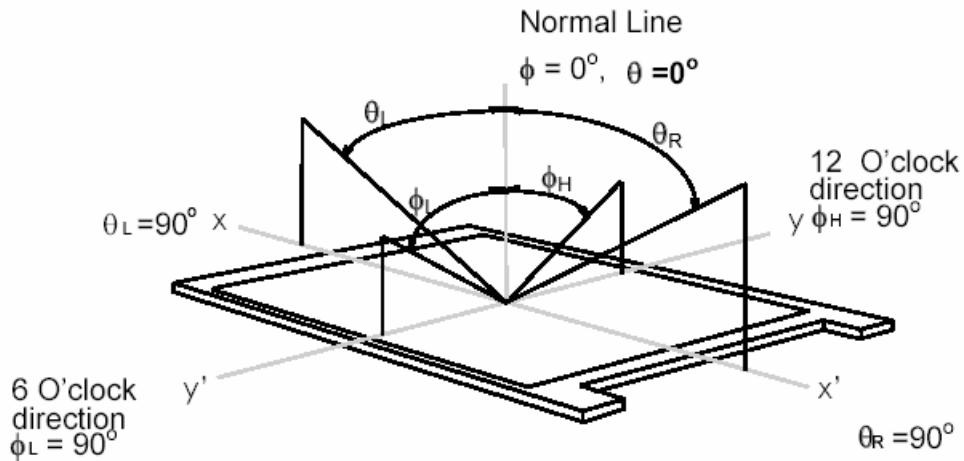

3. Functional Block Diagram

The following diagram shows the functional block of the 12.1 inches wide Color TFT/LCD Module:

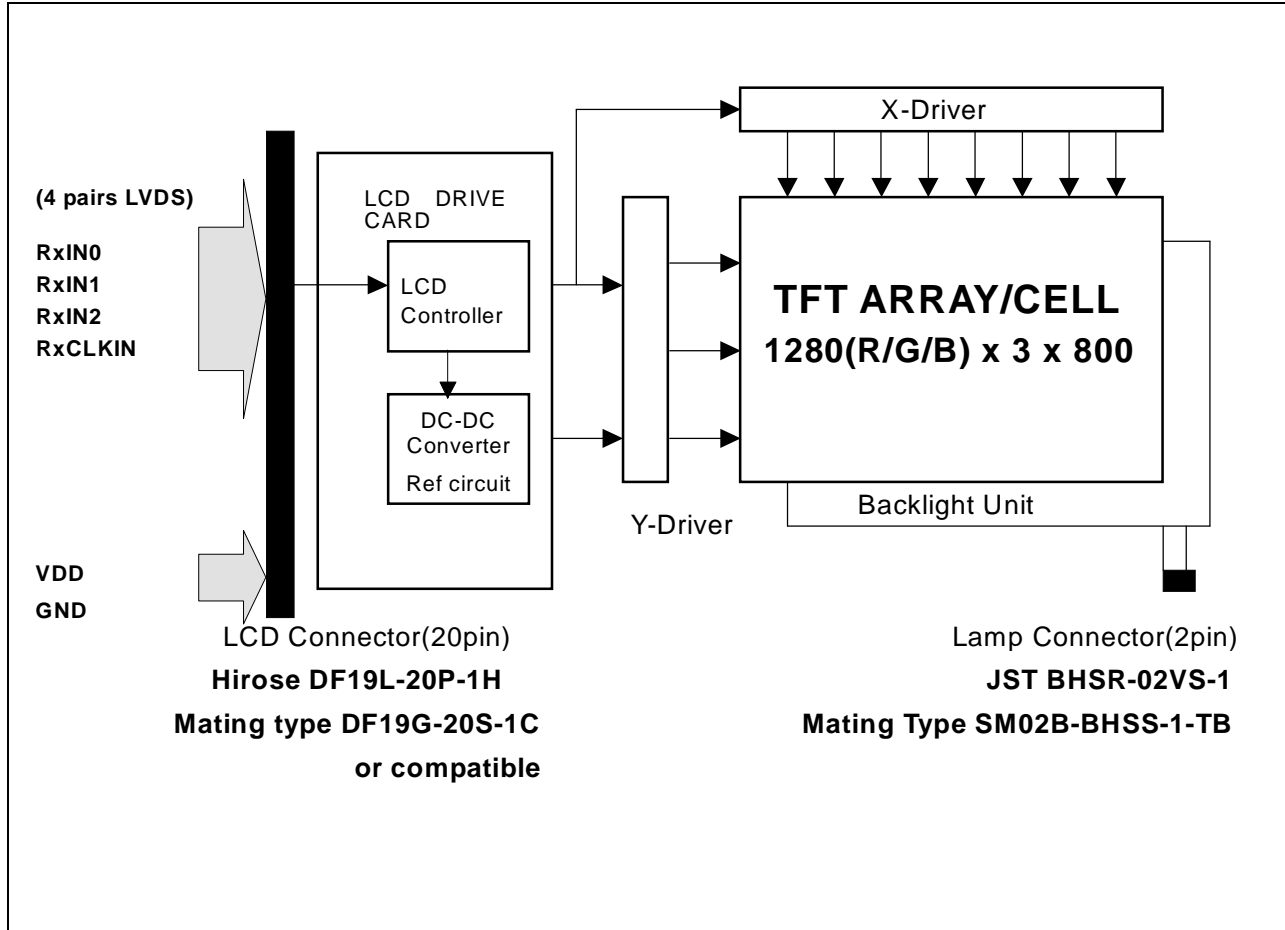

4. Absolute Maximum Ratings

Absolute maximum ratings of the module is as following:

4.1 Absolute Ratings of TFT LCD Module

| Item | Symbol | Min | Max | Unit | Conditions |
|-----------------|--------|------|------|--------|------------|
| Logic/LCD Drive | Vin | -0.3 | +4.0 | [Volt] | Note 1,2 |

4.2 Absolute Ratings of Backlight Unit

| Item | Symbol | Min | Max | Unit | Conditions |
|--------------|--------|-----|-----|----------|------------|
| CCFL Current | ICFL | - | 7 | [mA] rms | Note 1,2 |

4.3 Absolute Ratings of Environment

| Item | Symbol | Min | Max | Unit | Conditions |
|-----------------------|--------|-----|-----|-------|------------|
| Operating Temperature | TOP | 0 | +50 | [°C] | Note 3 |
| Operation Humidity | HOP | 5 | 95 | [%RH] | Note 3 |
| Storage Temperature | TST | -40 | +60 | [°C] | Note 3 |
| Storage Humidity | HST | 5 | 95 | [%RH] | Note 3 |

Note 1: With in Ta (25°C)

Note 2: Permanent damage to the device may occur if exceed maximum values

Note 3: For quality performance, please refer to AUO IIS(Incoming Inspection Standard).

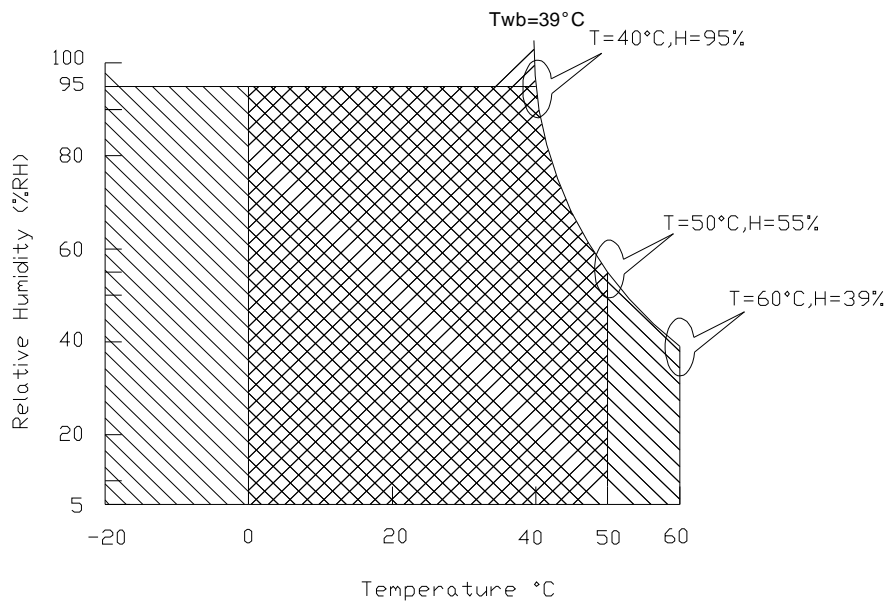

Operating Range



Storage Range



5. Electrical characteristics

5.1 TFT LCD Module

5.1.1 Power Specification

Input power specifications are as follows;

| Symble | Parameter | Min | Typ | Max | Units | Condition |
|--------|--|-----|-----|------|-------------|-----------------------|
| VDD | Logic/LCD Drive Voltage | 3.0 | 3.3 | 3.6 | [Volt] | Load Capacitance 20uF |
| PDD | VDD Power | | 1.0 | 1.6 | [Watt] | Max:All Black Pattern |
| IDD | IDD Current | | 400 | 420 | mA | Max:All Black Pattern |
| IRush | Inrush Current | | | 1800 | mA | |
| VDDrp | Allowable Logic/LCD Drive Ripple Voltage | | | 500 | [mV] p-p | |
| VDDns | Allowable Logic/LCD Drive Ripple Noise | | | 100 | [mV] p-p | |

Note 1 : Measurement conditions:

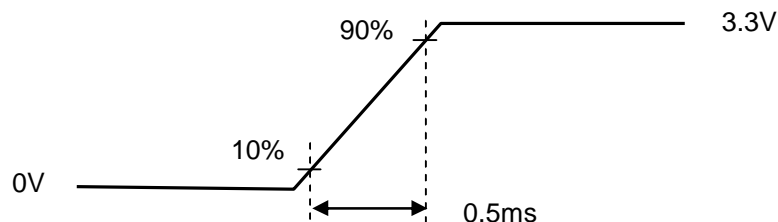
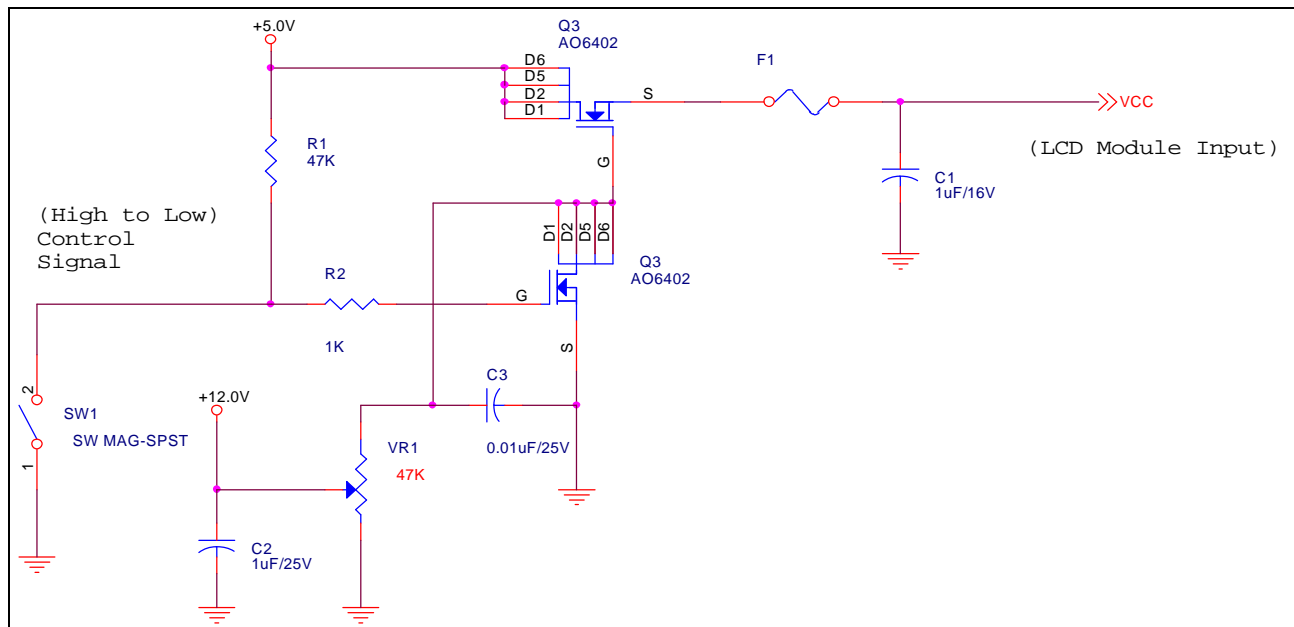

5.1.2 Signal Electrical Characteristics

Input signals shall be low or Hi-Z state when VDD is off.

It is recommended to refer the specifications of SN75LVDS86DGG(Texas Instruments) in detail.

Signal electrical characteristics are as follows;

| Parameter | Condition | Min | Max | Unit |
|-----------|---|------|-----|------|
| Vth | Differential Input High Threshold (Vcm=+1.2V) | | 100 | [mV] |
| Vtl | Differential Input Low Threshold (Vcm=+1.2V) | -100 | | [mV] |

Note: LVDS Signal Waveform

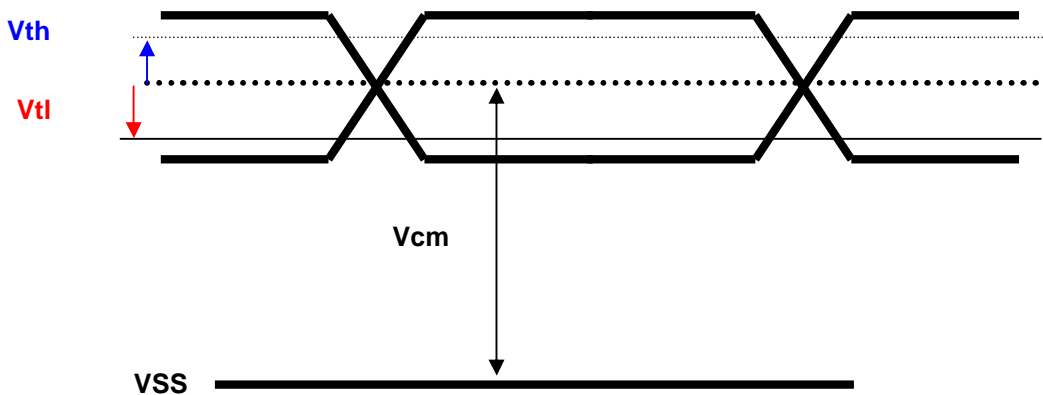

5.2 Backlight Unit

Parameter guideline for CCFL Inverter

| Parameter | Min | Typ | Max | Units | Condition |
|-------------------------------------|------|-----|-----|----------------------|-----------------------|
| White Luminance 5 points average | 170 | 200 | - | [cd/m ²] | (Ta=25°C) |
| CCFL current(ICFL) | 5.5 | 6.0 | 6.5 | [mA] rms | (Ta=25°C) Note 2 |
| CCFL Frequency(FCFL) | 50 | 60 | 70 | [KHz] | (Ta=25°C) Note 3,4 |
| CCFL Ignition Voltage(Vs) | 1400 | - | - | [Volt] rms | (Ta= 0°C) Note 5 |
| CCFL Voltage (Reference) (VCFL) | - | 580 | - | [Volt] rms | (Ta=25°C) Note 6 |
| CCFL Power consumption (PCFL) | - | 3.5 | - | [Watt] | (Ta=25°C) Note 6 |

Note 1: Typ are AUO recommended Design Points.

*1 All of characteristics listed are measured under the condition using the AUO Test inverter.

*2 In case of using an inverter other than listed, it is recommended to check the inverter carefully. Sometimes, interfering noise stripes appear on the screen, and substandard luminance or flicker at low power may happen.

*3 In designing an inverter, it is suggested to check safety circuit very carefully. Impedance of CFL, for instance, becomes more than 1 [M ohm] when CFL is damaged.

*4 Generally, CFL has some amount of delay time after applying kick-off voltage. It is recommended to keep on applying kick-off voltage for 1 [Sec] until discharge.

*5 CFL discharge frequency must be carefully chosen so as not to produce interfering noise stripes on the screen.

*6 Reducing CFL current increases CFL discharge voltage and generally increases CFL discharge frequency. So all the parameters of an inverter should be carefully designed so as not to produce too much leakage current from high-voltage output of the inverter.

Note 2: It should be employed the inverter which has "Duty Dimming", if ICFL is less than 4mA.

Note 3: CFL discharge frequency should be carefully determined to avoid interference between inverter and TFT LCD.

Note 4: The frequency range will not affect to lamp life and reliability characteristics.

Note 5: CFL inverter should be able to give out a power that has a generating capacity of over 1,430 voltage. Lamp units need 1,400 voltage minimum for ignition.

Note 6: Calculator value for reference (ICFL×VCFL=PCFL)

Note 7: Requirements for a system inverter design, which is intended to have a better display performance, a better power efficiency and a more reliable lamp, are following.

It shall help increase the lamp lifetime and reduce leakage current.

- a. The asymmetry rate of the inverter waveform should be less than 10%.
 - b. The distortion rate of the waveform should be within $\sqrt{2} \pm 10\%$.
- * Inverter output waveform had better be more similar to ideal sine wave.

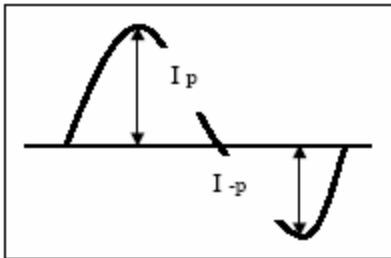

* Asymmetry rate:

$$\frac{|I_p - I_{-p}|}{I_{rms}} * 100\%$$

* Distortion rate

$$I_p \text{ (or } I_{-p}) / I_{rms}$$

6. Signal Characteristic

6.1 Pixel Format Image

Following figure shows the relationship of the input signals and LCD pixel format.

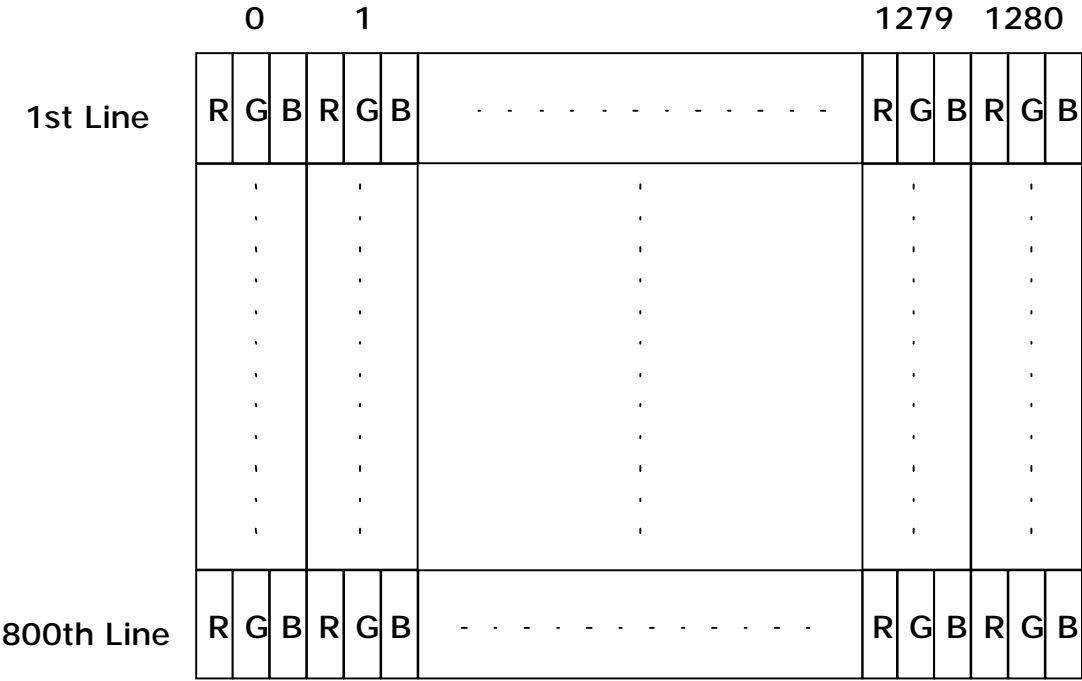

6.2 The input data format

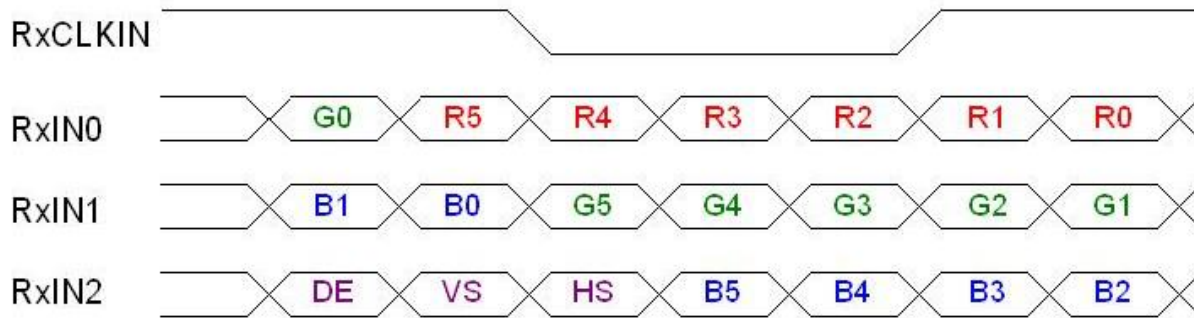

| Signal Name | Description | |
|--|--|--|
| RED5 RED4 RED3 RED2 RED1 RED0 | Red Data 5 (MSB) Red Data 4 Red Data 3 Red Data 2 Red Data 1 Red Data 0 (LSB) | Red-pixel Data Each red pixel's brightness data consists of these 6 bits pixel data. |
| | Red-pixel Data | |
| GREEN 5 GREEN 4 GREEN 3 GREEN 2 GREEN 1 GREEN 0 | Green Data 5 (MSB) Green Data 4 Green Data 3 Green Data 2 Green Data 1 Green Data 0 (LSB) | Green-pixel Data Each green pixel's brightness data consists of these 6 bits pixel data. |
| | Green-pixel Data | |
| BLUE 5 BLUE 4 BLUE 3 BLUE 2 BLUE 1 BLUE 0 | Blue Data 5 (MSB) Blue Data 4 Blue Data 3 Blue Data 2 Blue Data 1 Blue Data 0 (LSB) | Blue-pixel Data Each blue pixel's brightness data consists of these 6 bits pixel data. |
| | Blue-pixel Data | |
| DTCLK | Data Clock | The typical frequency is 68.9 MHz. The signal is used to strobe the pixel data and DSPTMG signals. All pixel data shall be valid at the falling edge when the DSPTMG signal is high. |
| DSPTMG | Display Timing | This signal is strobed at the falling edge of -DTCLK. When the signal is high, the pixel data shall be valid to be displayed. |
| VSYNC | Vertical Sync | The signal is synchronized to -DTCLK. |
| HSYNC | Horizontal Sync | The signal is synchronized to -DTCLK. |

Note: Output signals from any system shall be low or Hi-Z state when VDD is off.

6.3 Signal Description

The LVDS receiver equipped in this LCD module is compatible with SN75LVDS86 standard. LVDS is a differential signal technology for LCD interface and high speed data transfer device. Transmitter shall be SN75LVDS84 (negative edge sampling) or compatible.

| Signal Name | Description |
|---------------------|--|
| RxIN0N, RxIN0P | LVDS differential data input (Red0-Red5, Green0) |
| RxIN1N, RxIN1P | LVDS differential data input (Green1-Green5, Blue0-Blue1) |
| RxIN2N, RxIN2P | LVDS differential data input (Blue2-Blue5, Hsync, Vsync, DSPTMG) |
| RxCLKINN, RxCLKIN0P | LVDS differential clock input |
| VDD | +3.3V Power Supply |
| GND | Ground |

Note1: Start from right side

Note2: Please follow VESA.

Note3: Input signals shall be low or Hi-Z state when VDD is off. Internal circuit of LVDS inputs are as following.

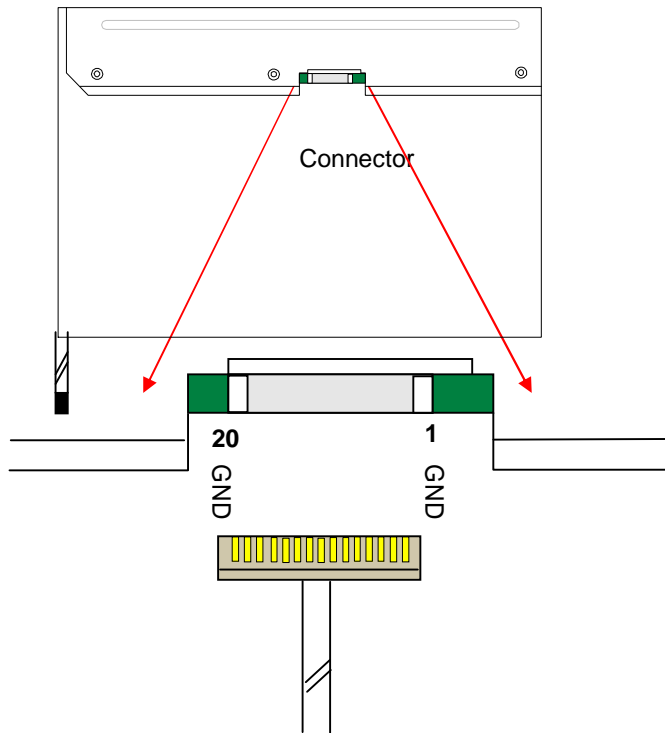

The module uses a 100ohm resistor between positive and negative data lines of each receiver input

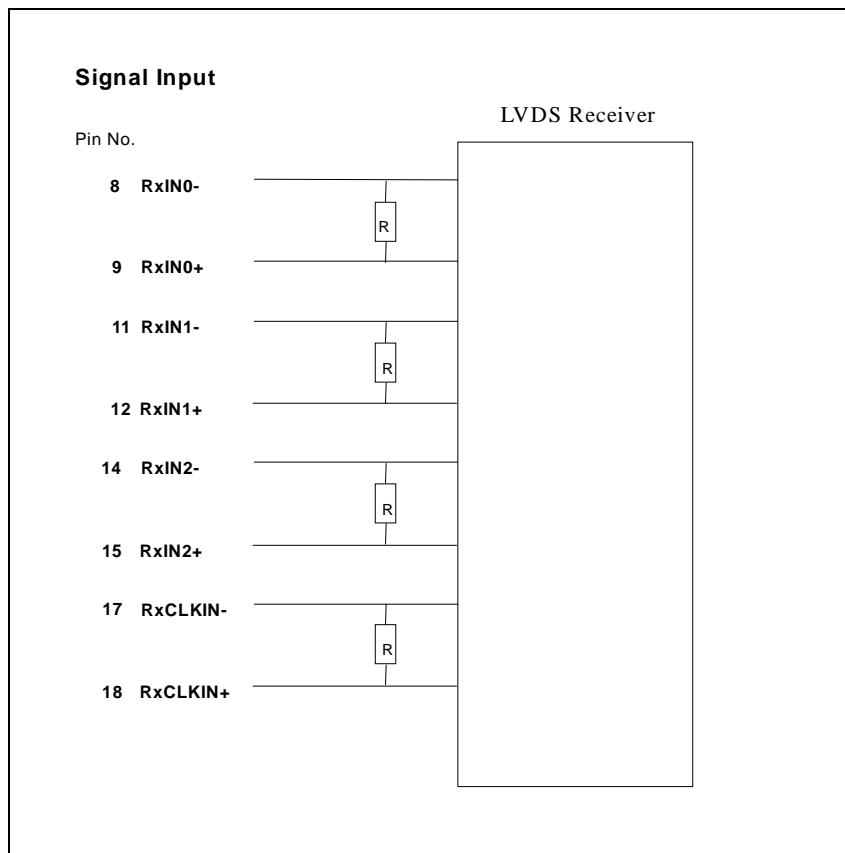

6.4 Interface Timing

6.4.1 Timing Characteristics

Basically, interface timings should match the 1280x800 /60Hz manufacturing guide line timing.

| Parameter | | Symbol | Min. | Typ. | Max. | Unit |
|---------------------------|----------|----------------------|------|------|------|--------------------|
| Frame Rate | | - | 50 | 60 | - | Hz |
| Clock frequency | | $1/T_{\text{Clock}}$ | 62 | 68 | 72 | MHz |
| Vertical Section | Period | T_V | 803 | 816 | 832 | T_{Line} |
| | Active | T_{VD} | 800 | 800 | 800 | |
| | Blanking | T_{VB} | 3 | 16 | 32 | |
| Horizontal Section | Period | T_H | 1302 | 1408 | 1700 | T_{Clock} |
| | Active | T_{HD} | - | 1280 | - | |
| | Blanking | T_{HB} | 22 | 128 | 420 | |
| End-frame checking period | | tEF | 2 | | | T_{Line} |
| DE checking period | | tDE | 6400 | | | T_{Line} |

Note : DE mode only

6.4.2 Timing diagram

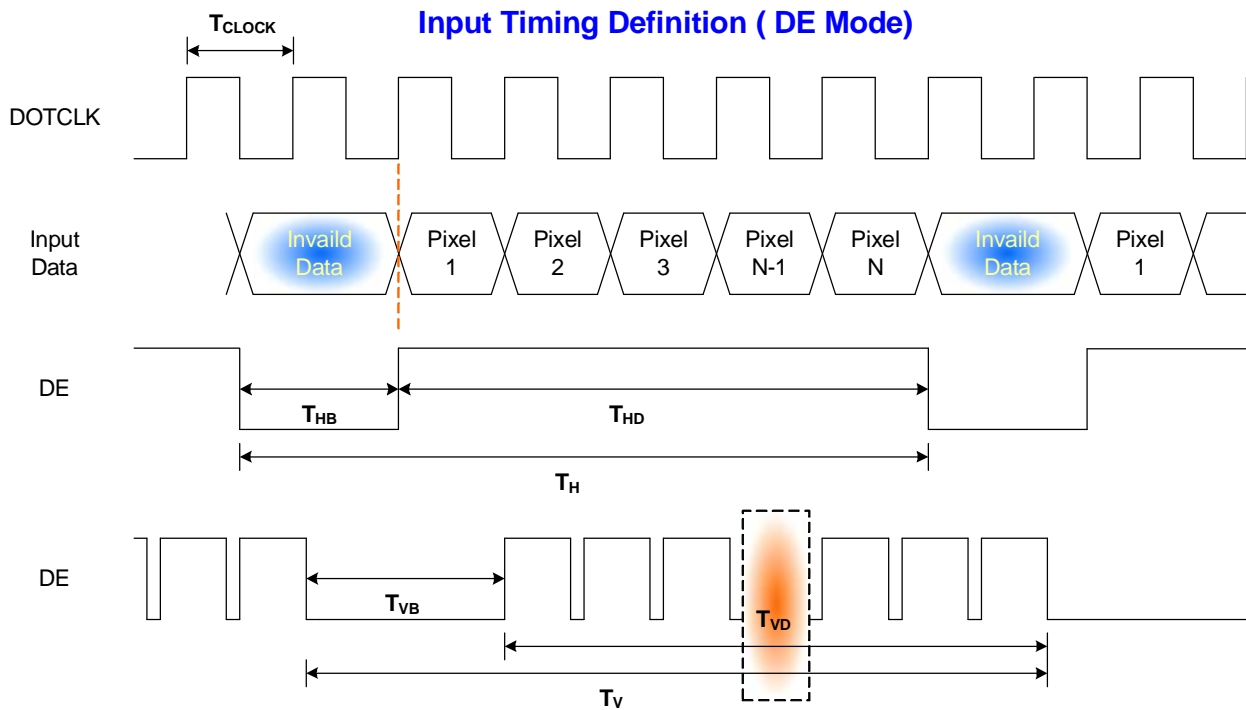

6.5 Power ON/OFF Sequence

VDD power and lamp on/off sequence is as follows. Interface signals are also shown in the chart. Signals from any system shall be Hi-Z state or low level when VDD is off.

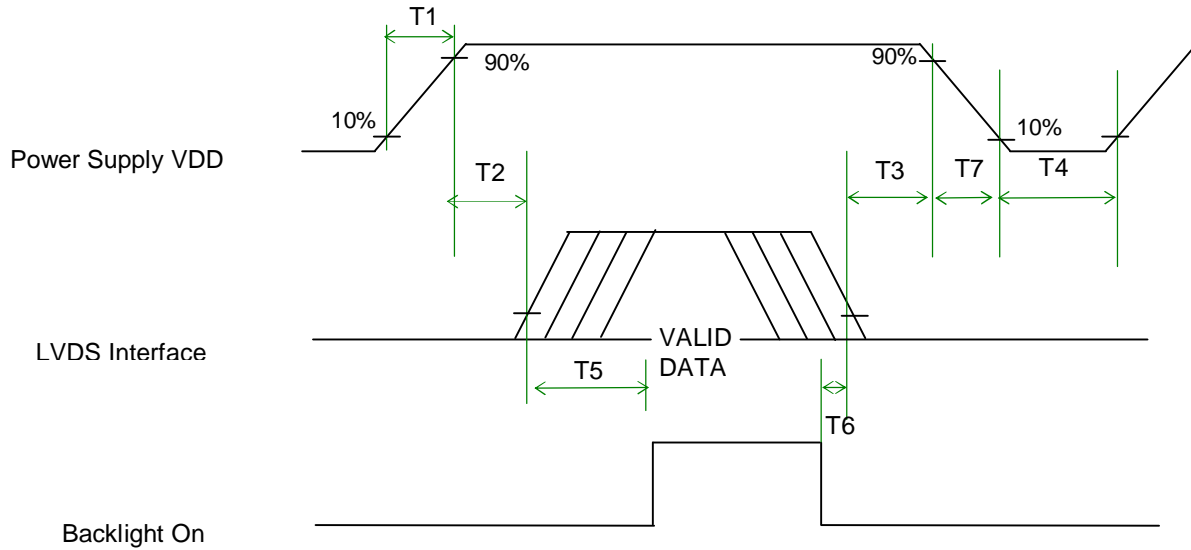

Power Sequence Timing

| Parameter | Value | | | Units |
|-----------|-------|------|------|-------|
| | Min. | Typ. | Max. | |
| T1 | 0.5 | - | 10 | (ms) |
| T2 | 0 | - | 50 | (ms) |
| T3 | 0 | - | 50 | (ms) |
| T4 | 500 | - | - | (ms) |
| T5 | 200 | - | - | (ms) |
| T6 | 200 | - | - | (ms) |
| T7 | 0 | - | 10 | (ms) |

7. Connector & Pin Assignment

Physical interface is described as for the connector on module.

These connectors are capable of accommodating the following signals and will be following components.

7.1 TFT LCD Module

(A) CONNECTOR

| | |
|-------------------------------------|----------------------------|
| Connector Name / Designation | For Signal Connector |
| Manufacturer | Hirose |
| Type / Part Number | DF19L-20P-1H |
| Mating Housing/Part Number | DF19G-20S-1C or compatible |

(B) Signal Pin

| Pin# | Signal Name | Pin# | Signal Name |
|------|----------------------|------|---------------------|
| 1 | GND | 2 | VDD |
| 3 | VDD | 4 | VDD _{EDID} |
| 5 | AGING | 6 | CLK _{EDID} |
| 7 | DATA _{EDID} | 8 | RxIN0N |
| 9 | RxIN0P | 10 | GND |
| 11 | RxIN1N | 12 | RxIN1P |
| 13 | GND | 14 | RxIN2N |
| 15 | RxIN2P | 16 | GND |
| 17 | RxCLKINN | 18 | RxCLKINP |
| 19 | GND | 20 | GND |

7.2 Backlight Unit

Physical interface is described as for the connector on module.

These connectors are capable of accommodating the following signals and will be following components.

| Connector Name / Designation | For Lamp Connector |
|------------------------------|--------------------|
| Manufacturer | JST |
| Type / Part Number | BHSR-02VS-1 |
| Mating Type / Part Number | SM02B-BHSS-1-TB |

7.3 Signal for Lamp connector

| Pin # | Cable color | Signal Name |
|-------|-------------|-------------------|
| 1 | Red | Lamp High Voltage |
| 2 | White | Lamp Low Voltage |

8. Vibration and Shock Test

8.1 Vibration Test

Test Spec:

- I Test method: Non-Operation
- I Acceleration: 1.5G
- I Frequency: 26 - 500Hz Random
- I Sweep: 30 Minutes each Axis (X, Y, Z)

8.2 Shock Test Spec:

Test Spec:

- I Test method: Non-Operation
- I Acceleration: 180 G , Half sine wave
- I Active time: 2 ms
- I Pulse: X,Y,Z .one time for each side

9. Reliability

| Items | Required Condition | Note |
|--------------------------------|---|--------|
| Temperature Humidity Bias | 40°C/95%,250Hr | |
| High Temperature Operation | 50°C/Dry,250Hr | |
| Low Temperature Operation | 0°C ,250Hr | |
| On/Off Test | ON/30 sec. OFF/30sec., 30,000 cycles. | |
| Hot Storage | 65°C/20% RH ,250 hours | |
| Cold Storage | -40°C/50% RH ,250 hours | |
| Thermal Shock Test | -40°C/20 min ,65°C/20 min 300cycles | |
| Hot Start Test | 50°C/1 Hr min. power on/off per 5 minutes, 5 times | |
| Cold Start Test | 0°C/1 Hr min. power on/off per 5 minutes, 5 times | |
| Shock Test (Non-Operating) | 180G, 2ms, Half-sine wave | |
| Vibration Test (Non-Operating) | Random vibration, 1.5 G zero-to-peak, 26 to 500 Hz, 30 mins in each of three mutually perpendicular axes. | |
| ESD | Contact : ±8KV/ operation Air : ±15KV / operation | Note 1 |
| Room temperature Test | 25°C , 2000hours, Operating with loop pattern | |

Note1: According to EN61000-4-2 , ESD class B: Some performance degradation allowed. No data lost
 . Self-recoverable. No hardware failures.

Note2: CCFL Life time: 10,000 hours minimum under normal module usage.

Note3: MTBF (Excluding the CCFL): 30,000 hours with a confidence level 90%

10. Mechanical Characteristics

10.1 LCM Outline Dimension

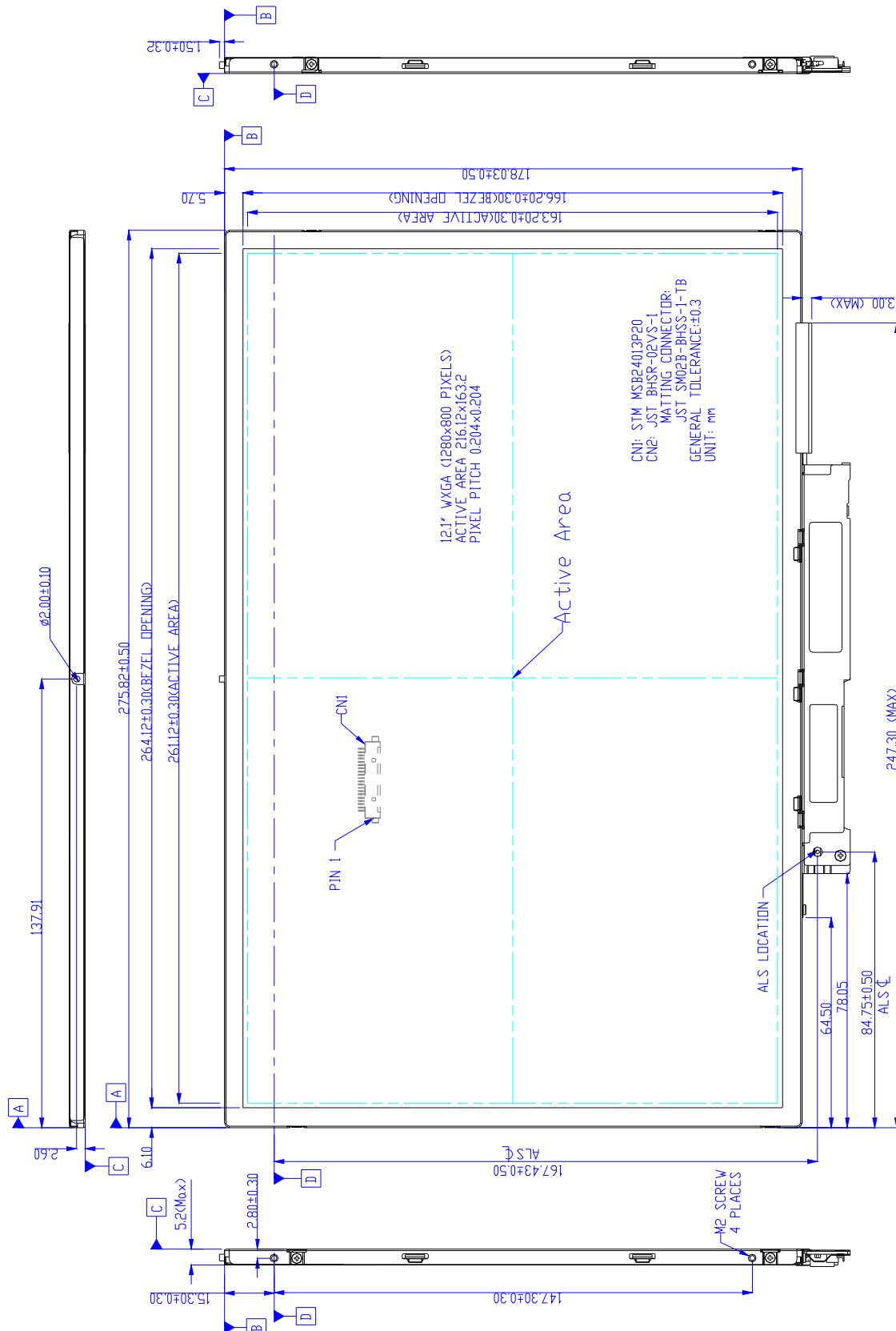

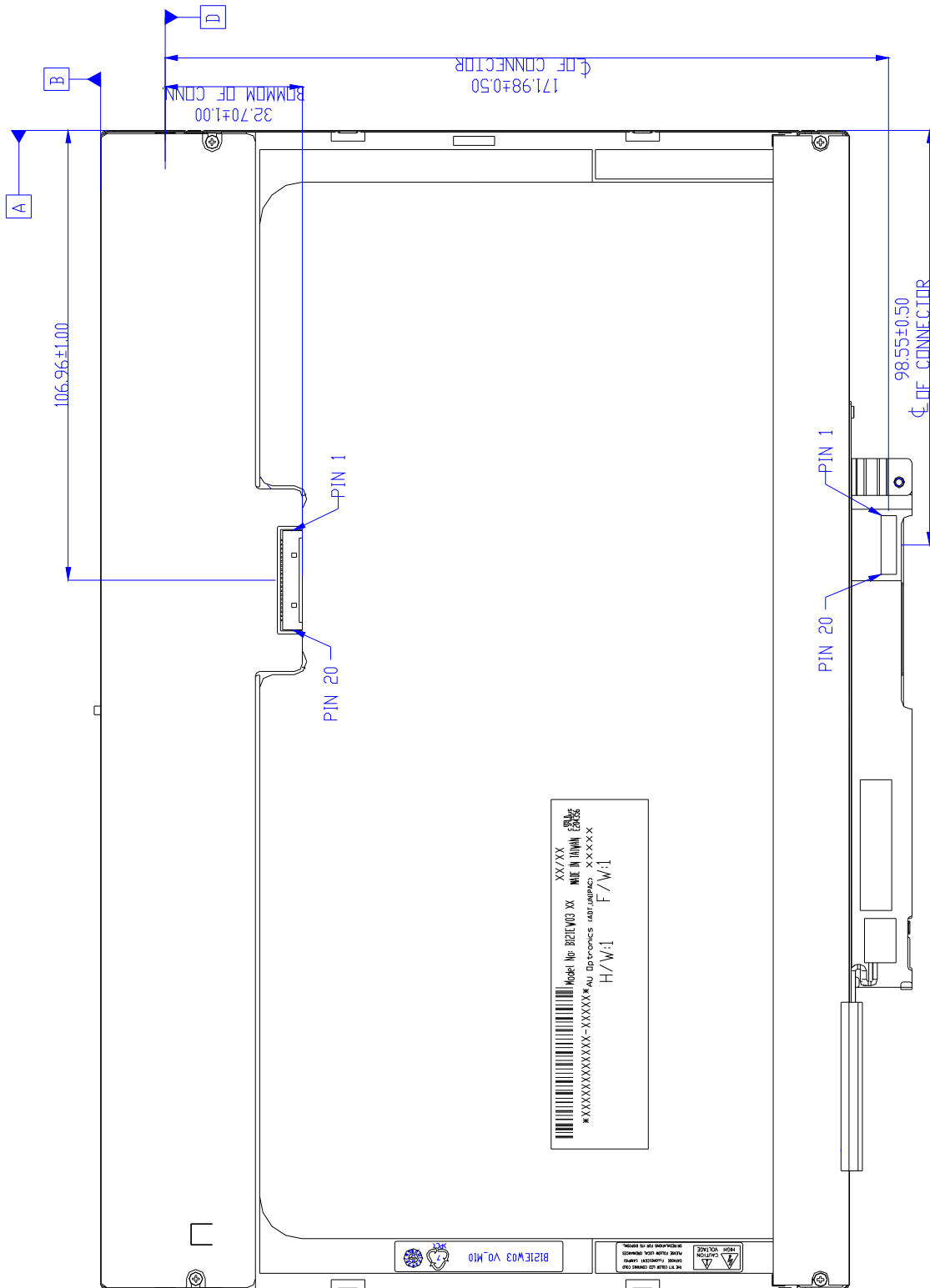

10.2 Screw Hole Depth and Center Position

Screw hole minimum depth, from side surface = 2.85 mm (See drawing)

Screw hole center location, from front surface = 328 ± 0.2 mm (See drawing)

Screw Torque: Maximum 2.2 kgf-cm

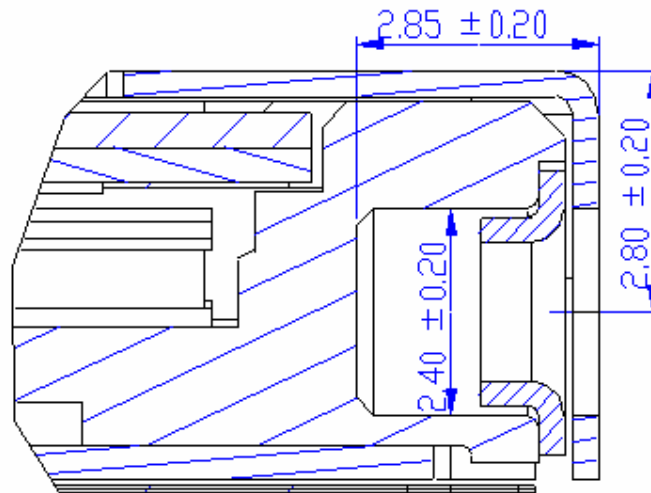

11. Shipping and Package

11.1 Shipping Label Format



Note 1:

| IC Combination | Inverter Combination | Control Code | H/W |
|---------------------------------------|----------------------|--------------|-----|
| Source IC: Novaek Gate IC: Novatek | Sumida (Maxim) | OAXXG | OA |
| Source IC: Novaek Gate IC: Novatek | Foxconn (MPS) | 1AXXG | 1A |

11.2. Carton package

The outside dimension of carton is 486 (L)mm x 286 (W)mm x 360 (H)mm

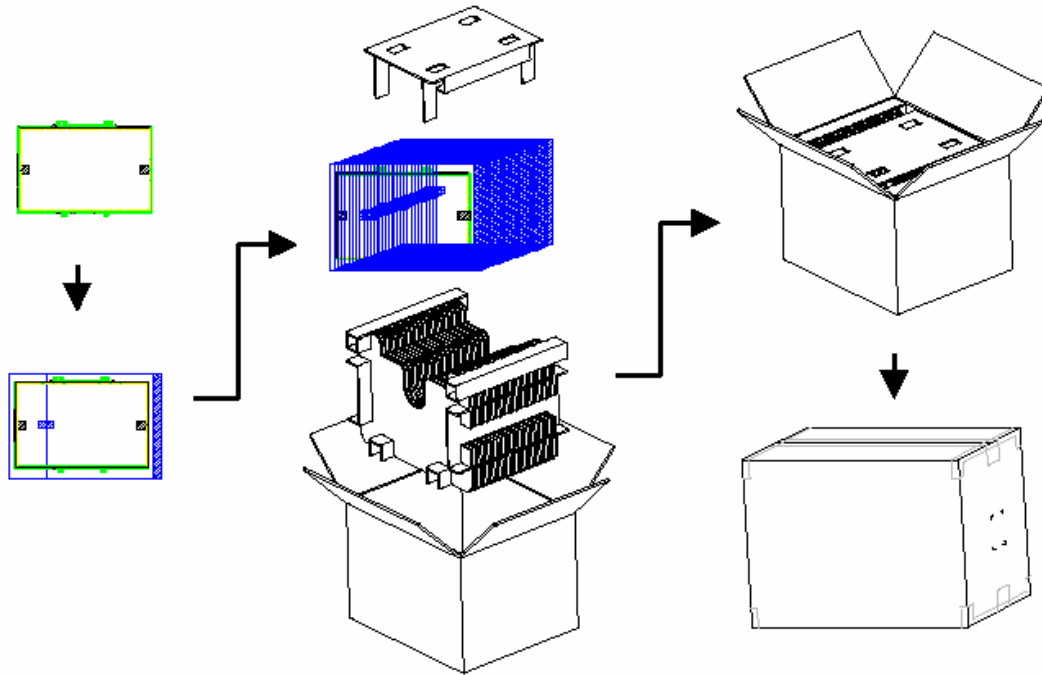

11.3 Shipping package of palletizing sequence

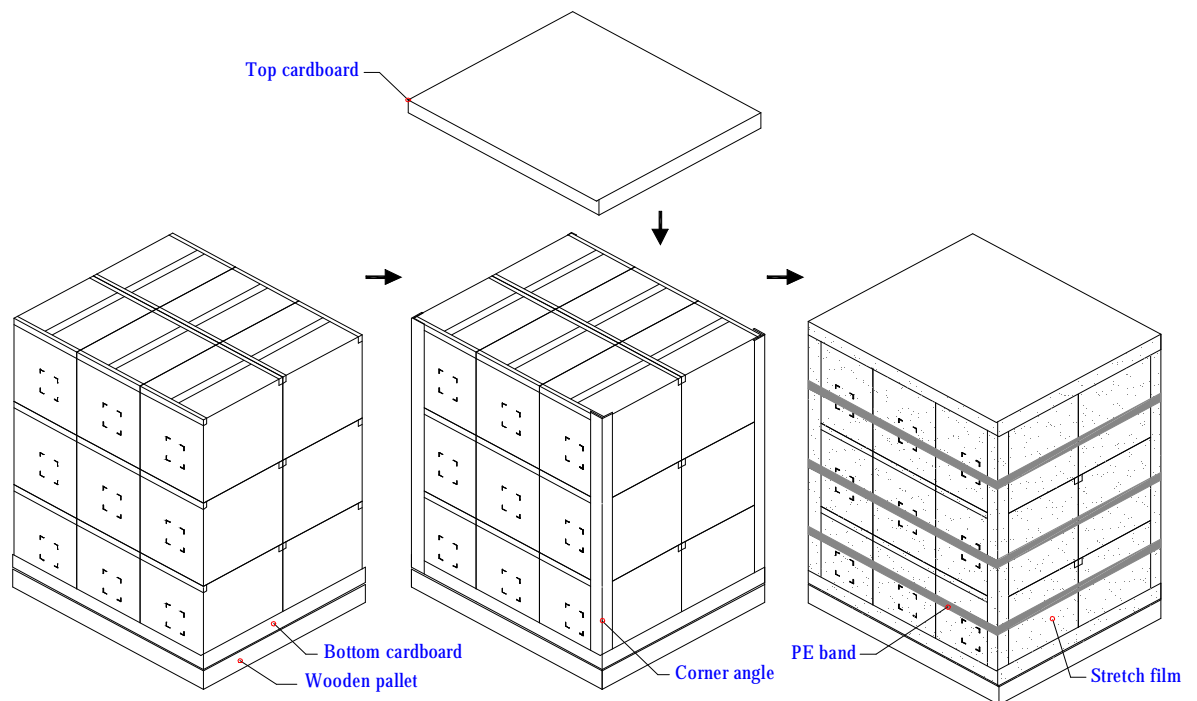

Note : Limit of box palletizing = Max 3 layers(ship and stock conditions)

12. Appendix: EDID description

| Byte (hex) | Field Name and Comments | Value (hex) | Value (binary) |
|---------------|---|----------------|-------------------|
| 0 | Header | 00 | 00000000 |
| 1 | Header | FF | 11111111 |
| 2 | Header | FF | 11111111 |
| 3 | Header | FF | 11111111 |
| 4 | Header | FF | 11111111 |
| 5 | Header | FF | 11111111 |
| 6 | Header | FF | 11111111 |
| 7 | Header | 00 | 00000000 |
| 8 | EISA manufacture code = 3 Character ID | 06 | 00000110 |
| 9 | EISA manufacture code (Compressed ASCII) | AF | 10101111 |
| 0A | Panel Supplier Reserved – Product Code | 14 | 00010100 |
| 0B | Panel Supplier Reserved – Product Code | 32 | 00110010 |
| 0C | LCD module Serial No - Preferred but Optional (“0” if not used) | 00 | 00000000 |
| 0D | LCD module Serial No - Preferred but Optional (“0” if not used) | 00 | 00000000 |
| 0E | LCD module Serial No - Preferred but Optional (“0” if not used) | 00 | 00000000 |
| 0F | LCD module Serial No - Preferred but Optional (“0” if not used) | 00 | 00000000 |
| 10 | Week of manufacture | 01 | 00000001 |
| 11 | Year of manufacture | 10 | 00010000 |
| 12 | EDID structure version # = 1 | 01 | 00000001 |
| 13 | EDID revision # = 3 | 03 | 00000011 |
| 14 | Video I/P definition = Digital I/P (80h) | 80 | 10000000 |
| 15 | Max H image size = (Rounded to cm) | 1A | 00011010 |
| 16 | Max V image size = (Rounded to cm) | 10 | 00010000 |
| 17 | Display gamma = (gamma ×100)-100 = Example: (2.2×100) – 100 = 120 | 78 | 01111000 |
| 18 | Feature support (no DPMS, Active off, RGB, timing BLK 1) | 0A | 00001010 |
| 19 | Red/Green Low bit (RxRy/GxGy) | 87 | 10000111 |
| 1A | Blue/White Low bit (BxBY/WxWy) | FE | 11111110 |
| 1B | Red X Rx = 0.xxx | 94 | 10010100 |
| 1C | Red Y Ry = 0.xxx | 57 | 01010111 |
| 1D | Green X Gx = 0.xxx | 4F | 01001111 |
| 1E | Green Y Gy = 0.xxx | 8C | 10001100 |
| 1F | Blue X Bx = 0.xxx | 27 | 00100111 |
| 20 | Blue Y By = 0.xxx | 27 | 00100111 |
| 21 | White X Wx = 0.xxx | 50 | 01010000 |
| 22 | White Y Wy = 0.xxx | 54 | 01010100 |
| 23 | Established timings 1 (00h if not used) | 00 | 00000000 |
| 24 | Established timings 2 (00h if not used) | 00 | 00000000 |
| 25 | Manufacturer's timings (00h if not used) | 00 | 00000000 |
| 26 | Standard timing ID1 (01h if not used) | 01 | 00000001 |
| 27 | Standard timing ID1 (01h if not used) | 01 | 00000001 |
| 28 | Standard timing ID2 (01h if not used) | 01 | 00000001 |

Product Specification

| | | | |
|----|---|----|----------|
| 29 | Standard timing ID2 (01h if not used) | 01 | 00000001 |
| 2A | Standard timing ID3 (01h if not used) | 01 | 00000001 |
| 2B | Standard timing ID3 (01h if not used) | 01 | 00000001 |
| 2C | Standard timing ID4 (01h if not used) | 01 | 00000001 |
| 2D | Standard timing ID4 (01h if not used) | 01 | 00000001 |
| 2E | Standard timing ID5 (01h if not used) | 01 | 00000001 |
| 2F | Standard timing ID5 (01h if not used) | 01 | 00000001 |
| 30 | Standard timing ID6 (01h if not used) | 01 | 00000001 |
| 31 | Standard timing ID6 (01h if not used) | 01 | 00000001 |
| 32 | Standard timing ID7 (01h if not used) | 01 | 00000001 |
| 33 | Standard timing ID7 (01h if not used) | 01 | 00000001 |
| 34 | Standard timing ID8 (01h if not used) | 01 | 00000001 |
| 35 | Standard timing ID8 (01h if not used) | 01 | 00000001 |
| 36 | Pixel Clock/10,000 (LSB) | 90 | 10010000 |
| 37 | Pixel Clock/10,000 (MSB) | 1A | 00011010 |
| 38 | Horizontal Active = 1280 pixels (lower 8 bits) | 00 | 00000000 |
| 39 | Horizontal Blanking (Thbp) = 112 pixels (lower 8 bits) | 70 | 01110000 |
| 3A | Horizontal Active/Horizontal blanking (Thbp) (upper4:4 bits) | 50 | 01010000 |
| 3B | Vertical Active = 800 lines | 20 | 00100000 |
| 3C | Vertical Blanking (Tvbp) = 16 lines (DE Blanking typ. for DE only panels) | 10 | 00010000 |
| 3D | Vertical Active : Vertical Blanking (Tvbp) (upper4:4 bits) | 30 | 00110000 |
| 3E | Horizontal Sync, Offset (Thfp) = 21 pixels | 15 | 00010101 |
| 3F | Horizontal Sync, Pulse Width = 32 pixels | 20 | 00100000 |
| 40 | Vertical Sync, Offset (Tvfp) = 4 lines Sync Width = 4 lines | 44 | 01000100 |
| 41 | Horizontal Vertical Sync Offset/Width upper 2 bits | 00 | 00000000 |
| 42 | Horizontal Image Size =261 mm | 05 | 00000101 |
| 43 | Vertical image Size = 163 mm | A3 | 10100011 |
| 44 | Horizontal Image Size / Vertical image size | 10 | 00010000 |
| 45 | Horizontal Border = 0 (Zero for Notebook LCD) | 00 | 00000000 |
| 46 | Vertical Border = 0 (Zero for Notebook LCD) | 00 | 00000000 |
| 47 | Non-interlaced, Normal, no stereo, Separate sync, H/V pol Negatives, DE only note: LSB is set to "1" if panel is DE-timing only. H/V can be ignored. | 18 | 00011000 |
| 48 | Pixel Clock/10,000 (LSB) | 00 | 00000000 |
| 49 | Pixel Clock/10,000 (MSB) | 00 | 00000000 |
| 4A | Horizontal Active = xxxx pixels (lower 8 bits) | 00 | 00000000 |
| 4B | Horizontal Blanking (Thbp) = xxxx pixels (lower 8 bits) | 00 | 00000000 |
| 4C | Horizontal Active/Horizontal blanking (Thbp) (upper4:4 bits) | 00 | 00000000 |
| 4D | Vertical Active = xxxx lines | 00 | 00000000 |
| 4E | Vertical Blanking (Tvbp) = xxxx lines (DE Blanking typ. for DE only panels) | 00 | 00000000 |
| 4F | Vertical Active : Vertical Blanking (Tvbp) (upper4:4 bits) | 00 | 00000000 |
| 50 | Horizontal Sync, Offset (Thfp) = xxxx pixels | 00 | 00000000 |
| 51 | Horizontal Sync, Pulse Width = xxxx pixels | 00 | 00000000 |
| 52 | Vertical Sync, Offset (Tvfp) = xx lines Sync Width = xx lines | 00 | 00000000 |
| 53 | Horizontal Vertical Sync Offset/Width upper 2 bits | 00 | 00000000 |
| 54 | Horizontal Image Size =xxx mm | 00 | 00000000 |
| 55 | Vertical image Size = xxx mm | 00 | 00000000 |

Product Specification

| | | | |
|----|--|----|----------|
| 56 | Horizontal Image Size / Vertical image size | 00 | 00000000 |
| 57 | Horizontal Border = 0 (Zero for Notebook LCD) | 00 | 00000000 |
| 58 | Vertical Border = 0 (Zero for Notebook LCD) | 00 | 00000000 |
| 59 | Module "A" Revision = Example: 00, 01, 02, 03, etc. | 00 | 00000000 |
| 5A | Flag | 00 | 00000000 |
| 5B | Flag | 00 | 00000000 |
| 5C | Flag | 00 | 00000000 |
| 5D | Dummy Descriptor | FE | 11111110 |
| 5E | Flag | 00 | 00000000 |
| 5F | Dell P/N 1 st Character | 4A | 01001010 |
| 60 | Dell P/N 2 nd Character | 46 | 01000110 |
| 61 | Dell P/N 3 rd Character | 32 | 00110010 |
| 62 | Dell P/N 4 th Character | 39 | 00111001 |
| 63 | Dell P/N 5 th Character | 38 | 00111000 |
| 64 | LCD Supplier EEDID Revision # | 04 | 00000100 |
| 65 | Manufacturer P/N | 42 | 01000010 |
| 66 | Manufacturer P/N | 31 | 00110001 |
| 67 | Manufacturer P/N | 32 | 00110010 |
| 68 | Manufacturer P/N | 31 | 00110001 |
| 69 | Manufacturer P/N | 45 | 01000101 |
| 6A | Manufacturer P/N | 57 | 01010111 |
| 6B | Manufacturer P/N (If <13 char, then terminate with ASCII code 0Ah, set remaining char = 20h) | 33 | 00110011 |
| 6C | Flag | 00 | 00000000 |
| 6D | Flag | 00 | 00000000 |
| 6E | Flag | 00 | 00000000 |
| 6F | Data Type Tag: | FE | 11111110 |
| 70 | Flag | 00 | 00000000 |
| 71 | SMBUS Value = XX nits | 2B | 00101011 |
| 72 | SMBUS Value = XX nits | 3A | 00111010 |
| 73 | SMBUS Value = XX nits | 46 | 01000110 |
| 74 | SMBUS Value = XX nits | 50 | 01010000 |
| 75 | SMBUS Value = XX nits | 70 | 01110000 |
| 76 | SMBUS Value = XXX nits | 8F | 10001111 |
| 77 | SMBUS Value = XXX nits | AC | 10101100 |
| 78 | SMBUS Value = XXX nits (Typically = 00h, XXX nits) | E2 | 11100010 |
| 79 | Number of LVDS receiver chips = '01' or '02' | 01 | 00000001 |
| 7A | BIST Enable: Yes = '01' No = '00' | 01 | 00000001 |
| 7B | (If <13 char, then terminate with ASCII code 0Ah, set remaining char = 20h) | 0A | 00001010 |
| 7C | (If <13 char, then terminate with ASCII code 0Ah, set remaining char = 20h) | 20 | 00100000 |
| 7D | (If <13 char, then terminate with ASCII code 0Ah, set remaining char = 20h) | 20 | 00100000 |
| 7E | Extension flag (# of optional 128 EDID extension blocks to follow, Typ = 0) | 00 | 00000000 |
| 7F | Checksum (The 1-byte sum of all 128 bytes in this EDID block shall = 0) | BE | 10111110 |

